

V5013P

THREE-WAY THREADED

GLOBE VALVE

- Red brass body with NPT-threaded end connections.
- Stainless steel stem and brass plug.
- Low seat leakage rate (≤ 0.05 percent Cv).
- Spring-loaded, self-adjusting packing.
- 50:1 rangeability per VDI/VDE 2173.
- Constant total flow throughout full stem travel.
- Accurate positioning to ensure state of the art temperature control.
- Sizes range from 1/2 in. to 2 in.
- Suitable for pneumatic or electric/electronic actuation.
- Repack and rebuild kits available for field servicing.



APPLICATION

The V5013N is a three-way threaded globe valve that controls hot water, cold water, and glycol solutions (up to 50 percent concentration) in heating or cooling HVAC applications. The valve is used for mixing service to direct flow from one of two inlets to a common outlet in two-position or modulating control systems.

Technical Specification

IMPORTANT

The specifications given in this publication do not include normal manufacturing tolerances. Therefore, an individual unit may not exactly match the listed specifications. Also, this product is tested and calibrated under closely controlled conditions and some minor differences in performance can be expected if those conditions are changed.

Models:

V5013N Valve: Three-way mixing valve for water or glycol. NPT-threaded pipe connections. Constant total flow. Push down valve stem to close bottom (B) port

Dimensions	See Fig. 1.
Pipe Connections	Internally-threaded NPT connections.

Seat	1/2 in.: Replaceable stainless steel (upper), replaceable brass(lower). 3/4 in. to 2 in.: Integral brass (upper), replaceable brass(lower).
Valve Sizes and Flow Capacities	See Table 1.
Plug	Brass
ANSI Body Class	150 psi.
Approximate Leakage Rate	0.05 percent Cv.
Packing	Spring-loaded, carbon fiber reinforced PTFE V-rings.
Stem	Stainless steel.
Stroke	3/4 in. (20 mm).
Rangeability	50:1 per VDI/VDE 2173.
Pattern:	2-way, straight-through.
Close-Off Pressure Ratings:	Red brass.
Pressure-Temperature Ratings:	Water: 36°F to 248°F, 250 psi (17.2 bar). 248°F to 340°F, 211 psi (14.5 bar).

Maximum Differential for Quiet Water Service	20 psid.
Valve Flow Characteristics:	Port A-AB: Equal percentage. Port B-AB: Linear.

NOTE: Movement of the valve stem at any point of the flow range does not significantly change the total flow rate at the AB outlet port (constant total flow).

Valve Design Life	250,000 full cycles at maximum rated temperature.
Replacement Parts:	See Fig. 3 and Table 3.

Table 1. Valve Size and Flow Capacities.

Size (in.)	Capacity
1/2	2.9 4.7
3/4	7.3
1	11.7
1-1/4	18.7
1-1/2	29.3
2	46.8

Motor and Linkage Selection:

Electric	Pneumatic
ML6420, ML6421A, ML6425	MP953 (5 in. through 8 in.)
ML7420, ML7421A, ML7425	
ML7984A3019, ML6874	
Mod IV with Q5001	

ORDERING INFORMATION

When purchasing replacement and modernization products from your TRADELINE® wholesaler or distributor, refer to the TRADELINE® Catalog or price sheets for complete ordering number.

If you have additional questions, need further information, or would like to comment on our products or services, please write or phone:

1. Your local Home and Building Control Sales Office (check white pages of your phone directory).
2. Home and Building Control Customer Logistics
Honeywell Inc., 1885 Douglas Drive North
Minneapolis, Minnesota 55422-4386 (612) 951-1000
In Canada—Honeywell Limited/Honeywell Limitée, 155 Gordon Baker Road, North York, Ontario M2H 3N7.
International Sales and Service Offices in all principal cities of the world. Manufacturing in Australia, Canada, Finland, France, Germany, Japan, Mexico, Netherlands, Spain, Taiwan, United Kingdom, U.S.A.

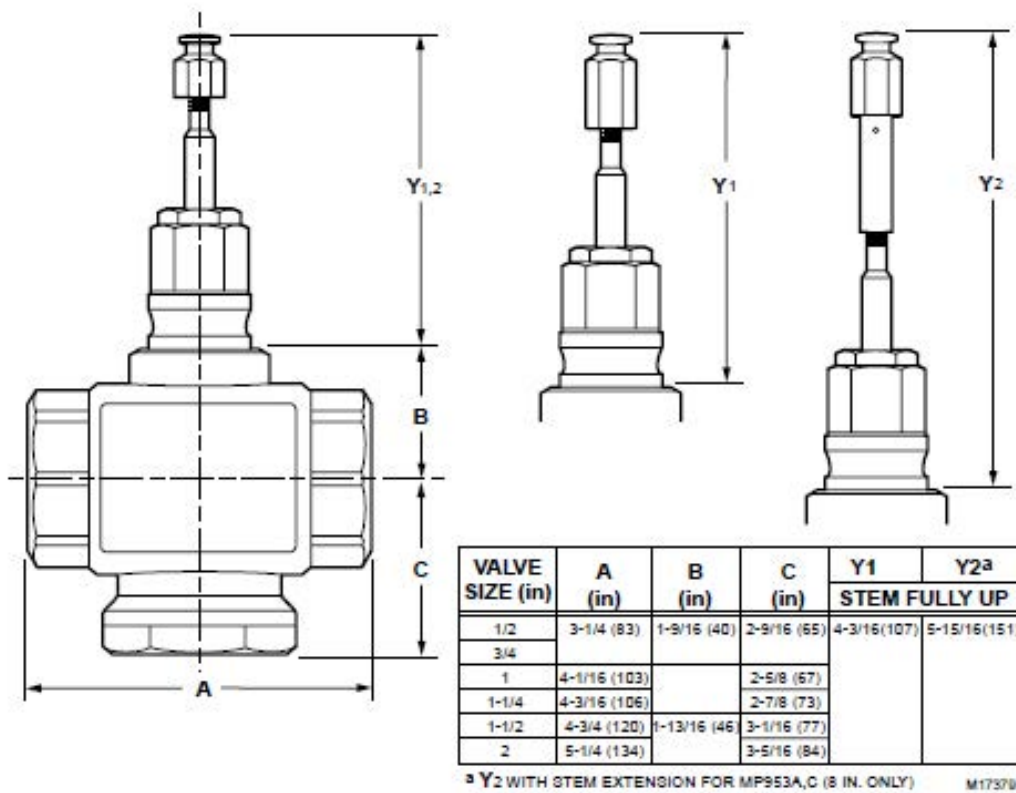

Fig. 1. V5013N body dimensions in in. (mm).

Table 2 Cross-off rating (psid) for V5013N Valves with Electric and Electronic Actuators

Valve Size (BSPT)	Mod IV with Q5001 Linkages			ML6421A, ML7421A	ML6425, ML7425 ML6420, ML7420	ML7984, ML6874
	320 lb	160 lb	80 lb	405 lb	135 lb	160 lb
1/2 in. (Cv.=2.9)	---	230	230	---	230	230
1/2 in. (Cv.=4.7)	---	230	230	---	230	230
3/4	---	230	131	---	230	230
1	230	196	91	230	163	196
1-1/4	230	126	57	230	104	126
1-1/2	173	81	36	221	67	81
2	98	46	19	126	37	46

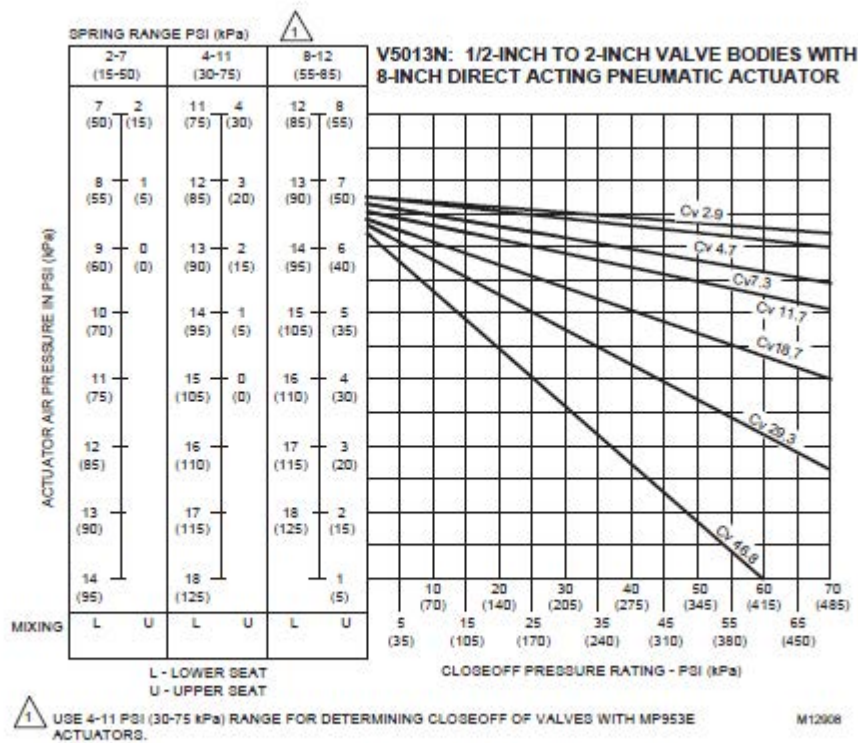
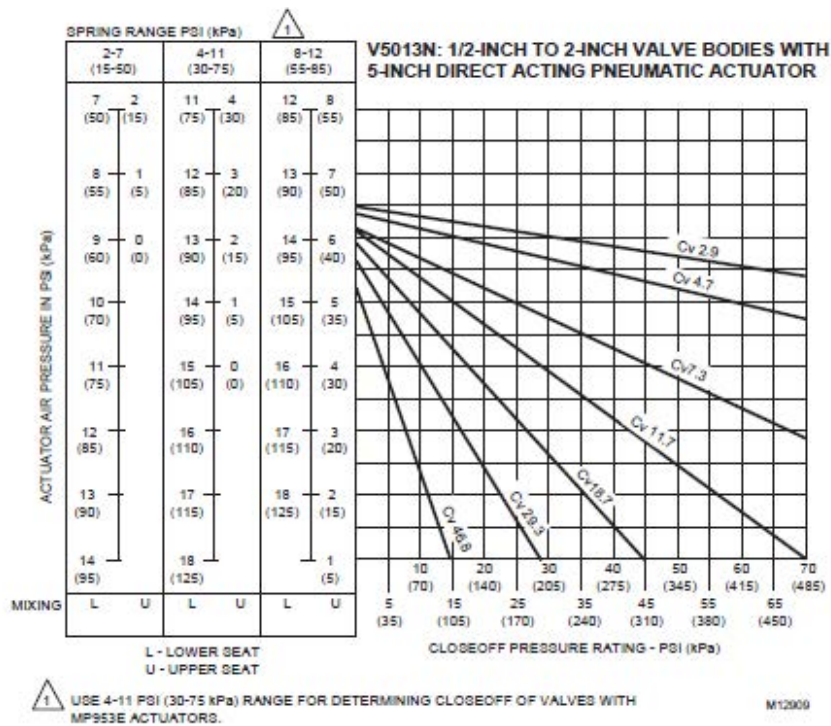

Fig. 2. Close-off ratings at various control air pressures for V5013N Valves and MP953 Pneumatic Actuators.

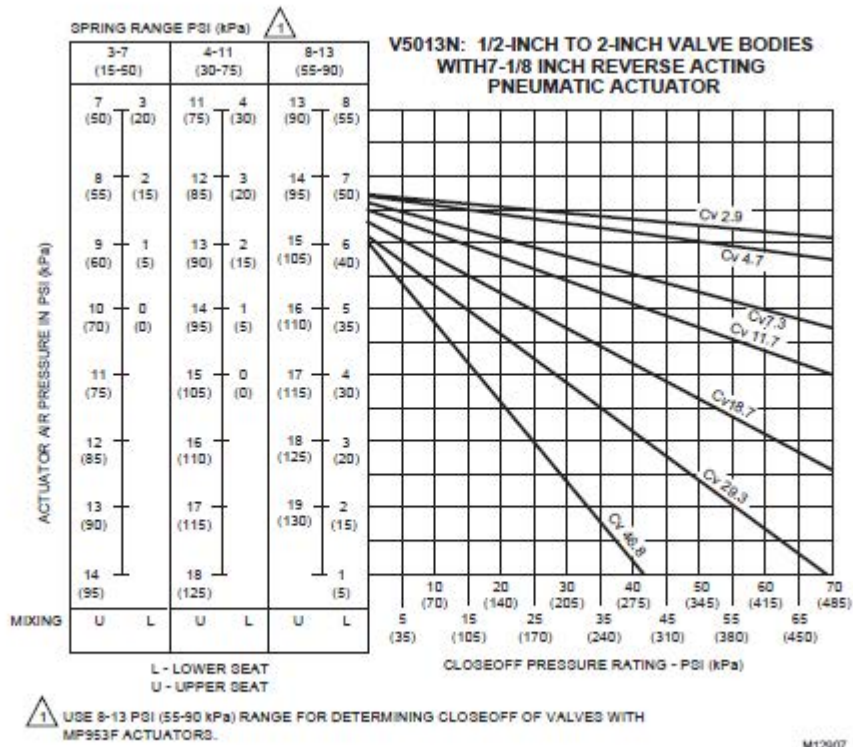

Fig. 2. Close-off ratings at various control air pressures for V5013N Valves and MP953 Pneumatic Actuators. (continued)

FST V5013N " #9@ DV8/SUW Wf BSfez

Valve OS No.	NPT Size (in.)	8'ai 5SbSUfk 5h	EfW 6[S_ VWdW[zi	DV8SU] =f	DWg[V =f	Stem Button
V5013N1030	1/2	2.9		0901786A	0901759A	0901116Aa
V5013N1048					0901760A	
V5013N1055	3/4	7.3	1/4		0901761A	
V5013N1063	1	11.7			0901762A	
V5013N1071	1-1/4	18.7			0901763A	
V5013N1089	1-1/2	29.3	3/8	0901787A	0901764A	
V5013N1097	2	46.8			0901765A	

Each 0901116A contains 10 stem buttons.

NOTE: 32003941-001 Seat Removal Tool required to rebuild 1/2 in. valves. Other sizes do not require this tool.

V5013N THREE-WAY GLOBE VALVES

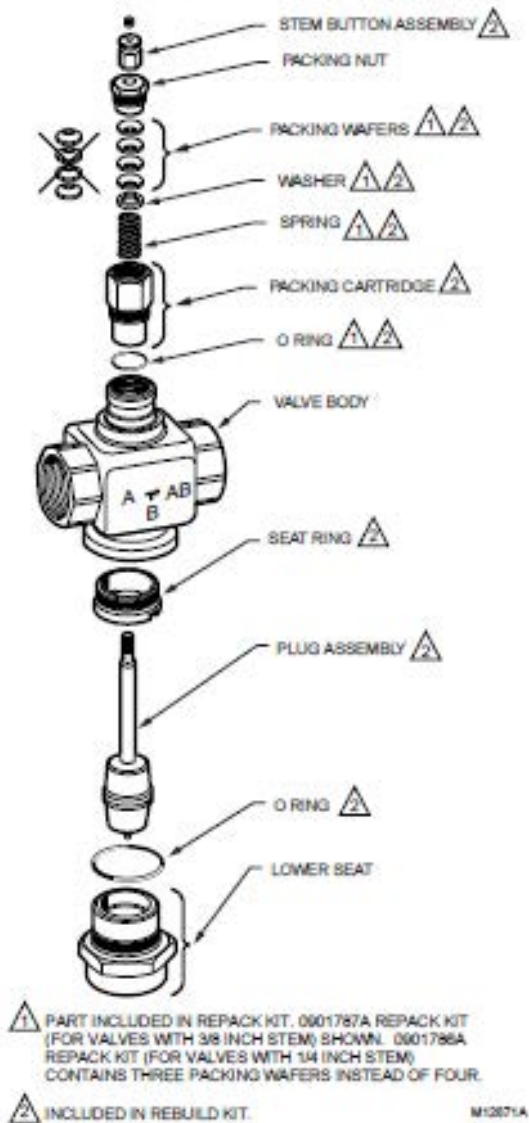

Fig. 3. V5013N replacement parts.

INSTALLATION

When Installing this Product.

1. Read these instructions carefully. Failure to follow them could damage the product or cause a hazardous condition.
2. Check the ratings given in the instructions and on the product to make sure the product is suitable for your application.
3. Installer must be a trained, experienced service technician.
4. After installation is complete, check out product operation as provided in these instructions.

IMPORTANT

1. Do not lift the valve by holding the stem.
2. Do not mount the valve with the stem pointed lower than horizontal.
3. Mount the valve with the flow arrow pointed in the direction of flow through the valve.
4. Mount the valve between aligned pipes. Mounting the valve on pipes that are not aligned causes leakage at the valve to pipe connection.
5. Ensure complete engagement on pipe to valve body threads.
6. Hold the valve body with a clamp or pipe wrench on the hexagonal fitting nearest the pipe to prevent damage to the valve body while mounting on the pipe. Refer to Fig. 7.
7. Be sure to allow enough room for installation and service. Clearance for valve installation is dependent on the actuator size and valve pipe size.

Location

Select a location where the valve, linkage (if used), and actuator to be used are within the appropriate ambient pressure and temperature ratings.

Leave sufficient clearance above the valve to accommodate actuator installation and room for servicing the valve body. (Completely install the valve body in the pipe line before installing the actuator and linkage.)

When selecting a location for the valve, consider actuator mounting restrictions. Modutrol IV™ Motors require crankshafts to be mounted horizontally.

Mounting

The preferred mounting position of the valve is with the stem vertical. Do not mount the valve with the stem more than 90 degrees from the vertical (pointing lower than horizontal). Scale and foreign material can collect and can score the stem and cause packing leakage. Protect the stem from damage due to bending or scratching.

Piping Hookups

All piping must comply with local codes and ordinances. Refer to Fig. 4 through 6 for typical piping hookups.

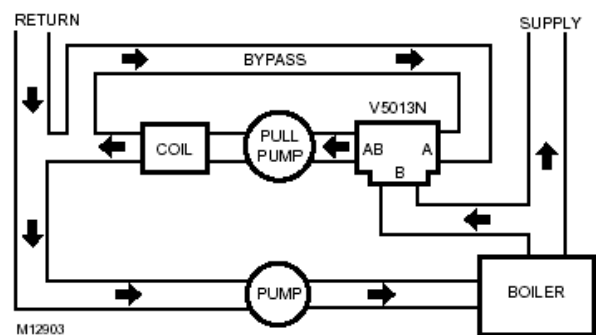

Fig. 4. Typical V5013P mixing valve with constant volume through coil.

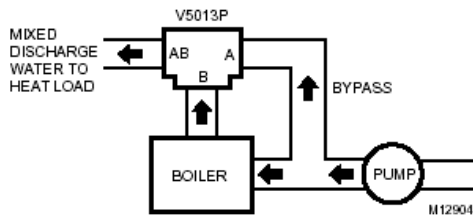

Fig. 5. Single zone bypass for reset control.

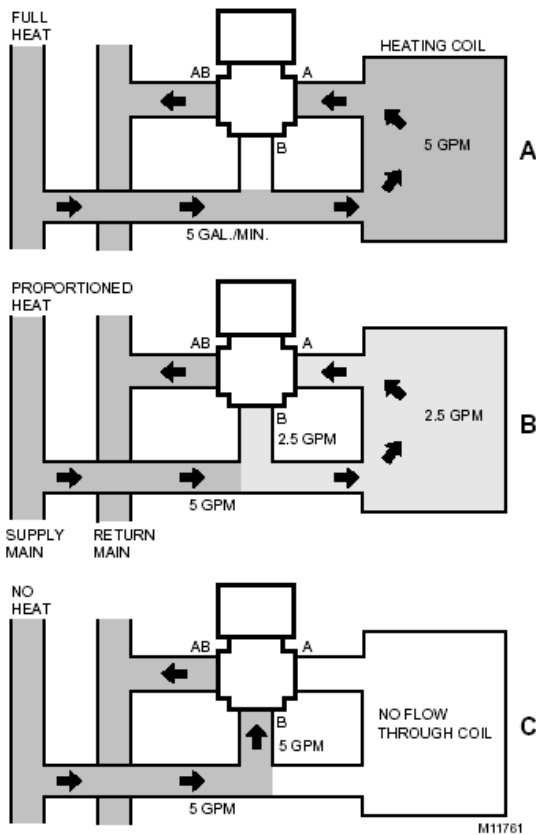

Fig. 6. Three-way mixing valve operation with coil bypass.

NOTE: Three-way valves maintain constant flow in piping. As temperature requirements change, volume of fluid varies in the coil.

Threaded Valve Bodies

Threading on threaded bodies conform to BSPT

IMPORTANT

1. Before installing linkage and actuator, make sure that the valve stem operates freely. Impaired stem operation can indicate that the body was twisted or the stem was bent. Either of these conditions can require valve replacement.
2. Align the pipes squarely with the valve at each end connection.
3. If the pipes are forced into the valve, the body can become twisted and improper seating can result.
4. Apply pipe dope sparingly.
5. Be careful to prevent pipe debris, such as chips and scale, from entering the piping because this material can lodge in the seat and prevent proper closing.

NOTES:

- Threading on threaded bodies conform to BSPT.
- Installing a strainer is strongly recommended.

Refer to Fig. 7 for valve pipe sizes and thread lengths. Fig. 7 also shows two effective methods of holding the valve and pipe when attaching it. The valve will not function properly if twisted or squeezed during installation.

Refer to installation information furnished with the linkage and motor when installing these controls.

PIPE SIZE (IN.)	EFFECTIVE LENGTH OF THREADS IN IN. (MM)
1/2	1/2 (12.7)
3/4	9/16 (14.3)
1	11/16 (17.5)
1-1/4	11/16 (17.5)
1-1/2	11/16 (17.5)
2	3/4 (19.1)

1. USE PROPERLY REAMED AND CLEANED PIPE AND MODERATE AMOUNT OF DOPE (LEAVE TWO THREADS BARE).
2. USE VISE GRIPS WITH THE HEX END NEXT TO THE PIPE (DO NOT TWIST OR SQUEEZE VALVE BODY).
3. USE VISE TO HOLD PIPE SECURELY TO PREVENT TURNING. USE PARALLEL-JAW WRENCH TO GRIP VALVE HEX FLATS NEXT TO PIPE.

M11763A

Fig. 7. Installing valves with threaded connections.

CHECKOUT

Use the following procedure to check for proper valve operation:

1. Check the valve body and connections for leaks.

IMPORTANT

Before installing linkage and actuator, make sure that the valve stem operates freely. Impaired stem operation can indicate that the body was twisted or the stem was bent. Either of these conditions can require valve replacement.

2. After installing linkage and actuator, check the operation according to the installation information furnished with these controls.

3. Operate the system through one complete cycle to ensure the valve controls properly.

4. Check the valve at regular intervals for leakage around the packing.

NOTE: The packing is spring-loaded and should seldom require attention.

5. If leakage is discovered and inspection shows that the packing gland is screwed down tightly, then repack the valve.

For more information,

<https://honeywellbuildings.in>

Call: 1-800-103-0339

Email: HBT-Indiabuildings@honeywell.com

Honeywell HBT India Buildings

Unitech Trade Center, 5th Floor, Sector-43,
Block C, Sushant Lok Phase - I,
Gurgaon - 122 002

www.honeywell.com

© 2020 Honeywell International Inc.

V5013N
THREE-WAY THREADED
GLOBE VALVE

Honeywell