

MICRO SWITCH
a Honeywell Division

FED. MFG. CODE 91929

SWITCH - BASIC

CATALOG LISTING
V3L-3339

CQ-X2868

V3L-3339

CATALOG LISTING

M

ISSUE
2

REPLACES X91253-V3L

RELEASE NO. PR-19362

CHECK

REVISIONS

A	CO-76298
JAK	11 NOV 93

CHECK

18 MAR 92

D C S

CHECK

19 MAR 92

DRAWN

J A L

D D M / C A D

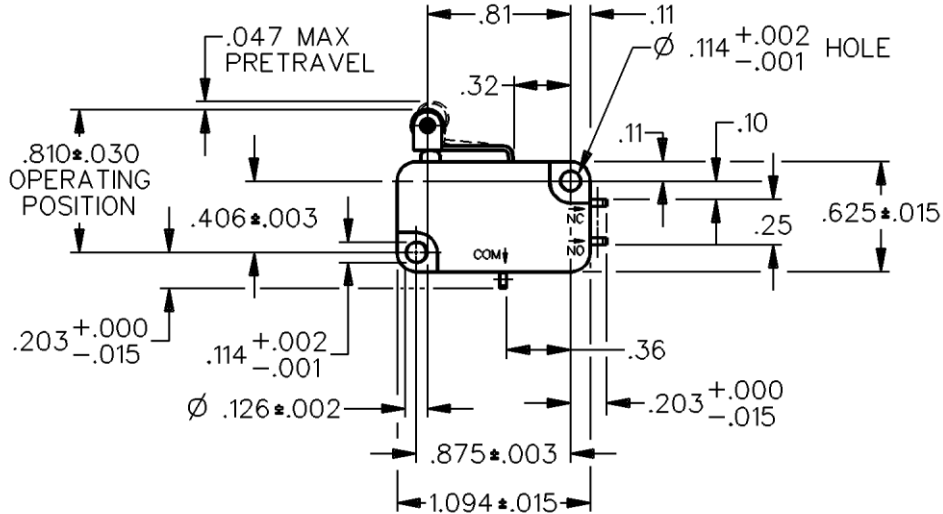
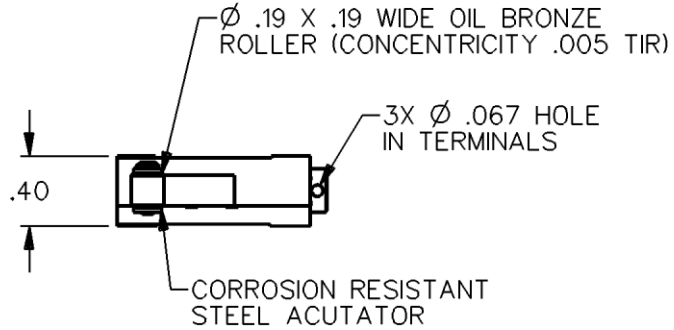

NOTES

- 1 - TERMINALS ARE SILVER PLATED FOR SOLDERING
- 2 - SWITCH MATERIAL WILL WITHSTAND TEMPERATURE OF 300°F
- 3 - HOLE IN TERMINALS MAY BREAK OUT

ANSI Y14.5M-1982 APPLIES

THIS DRAWING COVERS A PROPRIETARY ITEM AND IS THE PROPERTY OF MICRO SWITCH, A DIVISION OF HONEYWELL. THIS DRAWING IS NOT TO BE COPIED OR USED WITHOUT THE APPROVAL OF MICRO SWITCH.

THIRD ANGLE PROJECTION

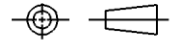

CHARACTERISTICS

OPERATING FORCE --- 150 GRAMS MAX
 RELEASE FORCE --- 15 GRAMS MIN
 DIFFERENTIAL TRAVEL --- .002-.010
 OVERTRAVEL --- .040 MIN
 RELEASE TRAVEL --- .007 MIN

ELECTRICAL DATA

CONTACT ARRANGEMENT
 S P D T
 L83 15.1A 1/2HP 125, 250 VAC
 1/2A 125 VDC, 1/4A 250 VDC
 5A 125 VAC "L"

SCALE FULL

DO NOT SCALE PRINT

UNLESS OTHERWISE SPECIFIED TOLERANCES ARE

ONE PLACE (.0)	± .030
TWO PLACE (.00)	± .015
THREE PLACE (.000)	± .005
ANGLES	±

WEIGHT

