

SNG-Q SERIES

32304260
Issue E

Quadrature Speed and Direction Sensors

DESCRIPTION

Honeywell's SNG-Q Series Quadrature Speed and Direction Sensors are designed to provide both speed and direction information. Speed information is provided from digital square wave outputs; direction is provided using a quadrature output with signals 90° phase shifted from each other. With the quadrature output, target direction is determined by output lead/lag phase shifting.

FEATURES

- Wide operating temperature range: -40°C to 150°C [-40°F to 302°F]
- Environmental sealing: Moisture ingress protection rated to IP69K
- Robust electrical noise immunity: Electrical noise radiated immunity (EMC) rated to 100 V/m
- High frequency switching capability: 3 Hz to 20 kHz
- Direction information: From phase-shifted dual output signals
- O-ring seal: Enables environmental sealing to mounting surface
- Supply voltage range: 4.5 V to 26 V
- CE, UKCA certified

POTENTIAL APPLICATIONS

Industrial

- AC induction motors in material handling, agriculture, and construction machines: May be used to help control power delivered by the ac induction motor
- Escalators and elevators: May be used to help control speed and position

Transportation

- Hybrid electric transmissions in heavy duty trucks, buses, agriculture and construction machines: May be used to help control power regulation of the hybrid system
- Wheel speed detection in material handling, agriculture, and construction machines: May be used to detect the speed and direction of the wheels, which translates to the speed and direction of the machine
- Hybrid engines in heavy duty trucks, buses, agriculture and construction machines: May be used to help control power regulation of the hybrid system

Not recommended for Aerospace or Defense applications.

VALUE TO CUSTOMERS

- Higher reliability: IP69K rating, EMC radiated immunity protection, O-ring seal and wide operating temperature range:
 - Improves equipment uptime
 - Minimizes service costs
 - Provides resistance to high electrical noise
 - Provides resistance to moisture intrusion
 - Wide operating temperature range
 - Attempts to substantially reinforce the customer's brand equity
- Cost-competitive: Designed and manufactured using a platform-based approach that enables better cost-competitiveness and mechanical and electrical configurability for customers.
- Enhanced accuracy: Dual differential Hall-effect sensor IC technology allows an enhanced ability to detect small target features.
- Flexible: Wide operating temperature range, robust electrical noise immunity and enhanced environmental sealing capability allow flexibility of use in the application.
- Expedites installation: O-ring seal for use in pressure applications and a fixed mounting flange allows for a simpler installation process, using one fastener.



PORTFOLIO

The SNG-Q Series joins the SNDH-T Series speed and direction sensors. For speed only sensors, see the SNDH-H Series, LCZ Series, ZH10 Series and 584XX Series.

Honeywell

QUADRATURE SPEED AND DIRECTION SENSORS

SNG-Q SERIES

TABLE 1. ELECTRICAL SPECIFICATIONS

CHARACTERISTIC	PARAMETER	COMMENT
Supply voltage	4.5 V to 26 V	—
Output signal:		
type	square wave	Two channel, phase shifted by 90° either channel, may lead or lag.
duty cycle ¹	50% ±10%	Dependent on target geometry and sensor-to-target orientation; see Figures 2, 3, 4, 5, 6, 7, 8, 9 for recommended orientation.
phase shift	90° ±45°	Dependent on target geometry and sensor-to-target orientation; see Figures 2, 3, 4, 5, 6, 7, 8, 9 for recommended orientation.
high	≥Vs - 0.5 V	—
low:		—
SNG-QPLA/QPCA/ QPMB/QPDB	≤0.5 V ≤1.75 V	
load current	40 mA max.	Applies to each output at all conditions.
rise time	10 us max.	1 kOhm pull-up resistor, dependent on load resistor.
fall time	5 us max.	1 kOhm pull-up resistor, dependent on load resistor.
frequency	3 Hz to 20 kHz	Frequencies >10 kHz may be dependent on target geometry and air gap.
Short circuit protection	50 mA max.	—
Supply current:		
normal	12 mA	all conditions
max.	18 mA	
Reverse voltage	-26 V max.	10 min duration

¹Duty cycle = Time high/time total.

TABLE 2. MECHANICAL SPECIFICATIONS

CHARACTERISTIC	PARAMETER
Sensing air gap	0,0 mm to 2,0 mm [0.0 in to 0.08 in]
Target:	
width ¹	>5,0 mm [0.20 in] recommended; 12,7 mm [0.5 in] typ.
slot width ²	2,0 mm [0.08 in] min.
tooth width ²	2,0 mm [0.08 in] min.
tooth height ³	>3,0 mm [0.12 in] recommended; 5,0 mm [0.20 in] typ.
Materials:	
housing	PBT
bushing	brass
O-ring	fluorocarbon with PTFE coating, Ø11,8 mm [Ø0.47 in] OD x Ø1,80 mm [Ø0.07 in] CS
cable ⁴	EVA, four conductor, 36 AWG, 28 strand, Ø5,2 mm [Ø0.20 in] jacket
Mounting:	
bore size ⁵	Ø15,15 mm to Ø15,40 mm [Ø0.60 in to Ø0.61 in]
torque	10 N m [88.5 in-lb] max. with M6 X 1.0 bolt

¹Narrower targets may limit axial offsets.

²Other geometry may be suitable.

³Shorter tooth heights may limit maximum air gap performance.

⁴Applies to SNG-QPLA-001, SNG-QPCA-001, SNG-QPMB-000, SNG-QPDB-000, and SNG-QPDB-002.

⁵Application dependent.

QUADRATURE SPEED AND DIRECTION SENSORS

SNG-Q SERIES

TABLE 3. ENVIRONMENTAL SPECIFICATIONS

CHARACTERISTIC	CONDITION	PARAMETER
EMI: radiated immunity bulk current injection ESD	ISO 11452-2, 400 MHz to 1 GHz ISO 11452-4, 1 MHz to 400 MHz ISO 10605, Section 9 conforms to CE, UKCA Mark standards EN60947-5-2:2007 and EN 60947-5-2/A1:2012	100 V/m 100 mA ±8 kV contact, ±15 kV air
Operating temperature	—	-40°C to 150°C [-40°F to 302°F]
Thermal shock, air to air	-40°C to 150°C [-40°F to 302°F], 60 min. soak, <3 s transfer	500 cycles
Humidity	95% humidity at 38 °C [100 °F]	240 hr
Salt fog	5% salt solution by mass at 35 °C [95 °F]	96 hr
Thermal saline dunk	100°C to 25°C [212°F to 77°F] air to liquid, 5% saline	10 cycles
High temperature exposure with power	150°C [302°F], 13.5 Vdc, 1 kOhm load	500 hr
Vibration	3 perpendicular axes, 48 hr per axis	29.28 GMS, 50 Hz to 2000 Hz MIL-STD-202-214
Degree of protection	—	IP69K
Resistance to fluids	—	general under-the-hood automotive fluids

TABLE 4. ORDER GUIDE

CATALOG LISTING	DESCRIPTION
SNG-QPLA-000	SNG-Q Series, quadrature speed and direction sensor, plastic housing, 35 mm [1.38 in] housing length, 500 mm [19.7 in] cable, right angle exit,
SNG-QPCA-001	SNG-Q Series, quadrature speed and direction sensor, plastic housing, 35 mm [1.38 in] housing length, Deutsch DTM04-4P connector with 1250 mm [49.2 in] cable, right angle exit
SNG-QPRA-000	SNG-Q Series, quadrature speed and direction sensor, plastic housing, 35 mm [1.38 in] housing length, integral Amp Superseal 1.5 connector, right angle exit
SNG-QPMB-000	SNG-Q Series, quadrature speed and direction sensor, plastic housing, 45 mm [1.77 in] housing length, 500 mm [19.7 in] cable, straight exit
SNG-QPDB-000	SNG-Q Series, quadrature speed and direction sensor, plastic housing, 45 mm [1.77 in] housing length, Amp Superseal 1.5 connector 282106 with 145 mm [5.71 in] cable, straight exit
SNG-QPDB-002	SNG-Q Series, quadrature speed and direction sensor, plastic housing, 45 mm [1.77 in] housing length, Deutsch DTM04-4P connector with 1250 mm [49.2 in] cable, straight exit

FIGURE 1. GENERAL NOMENCLATURE

For example, **SNG-QPLA-000** defines an SNG-Q Series quadrature speed and direction sensor, plastic housing, cable with leads, right angle exit, 35 mm [1.38 in] housing length.

SNG-Q Series	P Housing Material ¹	L Connection Type ²	A Housing Length	000 For Internal Use Only
4-wire quadrature speed and direction sensor	P Plastic	S Integral connector, straight exit ³	A 35 mm [1.38 in]	
		R Integral connector, right angle exit	B 45 mm [1.77 in]	
		L Cable with leads, right angle exit		
		M Cable with leads, straight exit		
		C Connector with cable, right angle exit		
		D Connector with cable, straight exit ³		

¹Contact Honeywell for other Housing Material options.

²Other cable lengths available upon request.

³Contact Honeywell.

QUADRATURE SPEED AND DIRECTION SENSORS SNG-Q SERIES

FIGURE 2. SENSOR OUTPUT (ALL CATALOG LISTINGS)

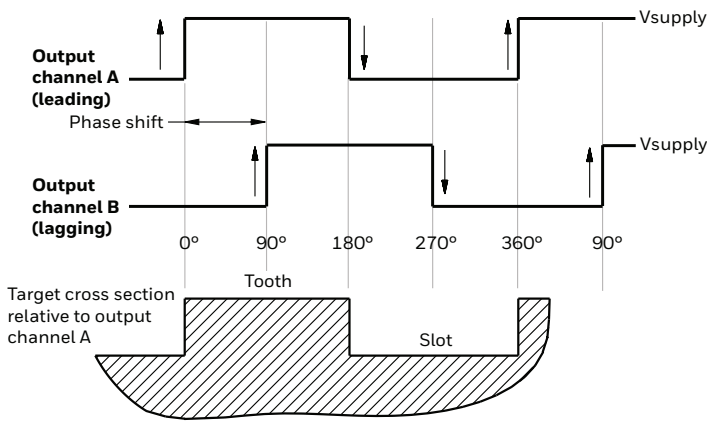

FIGURE 3. POSSIBLE MOUNTING ORIENTATIONS

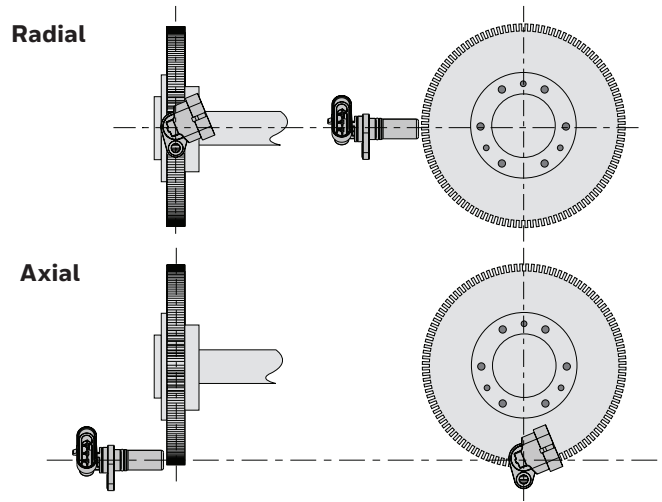
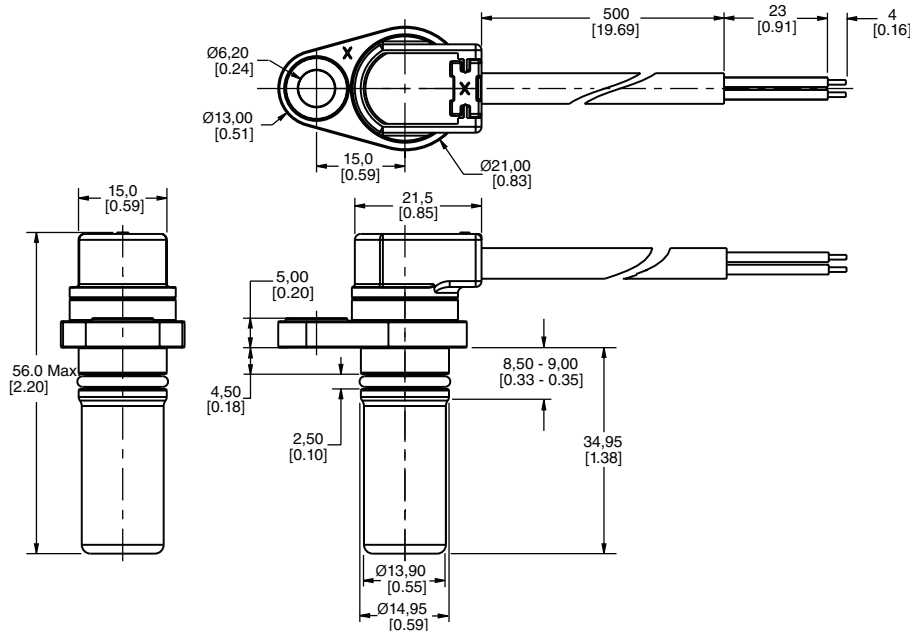
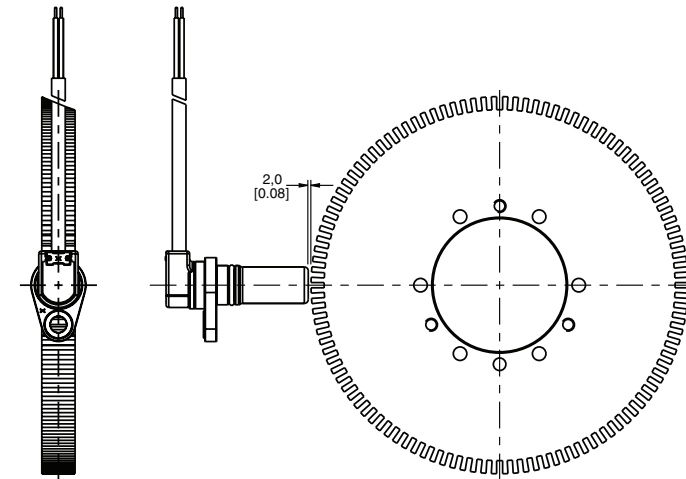
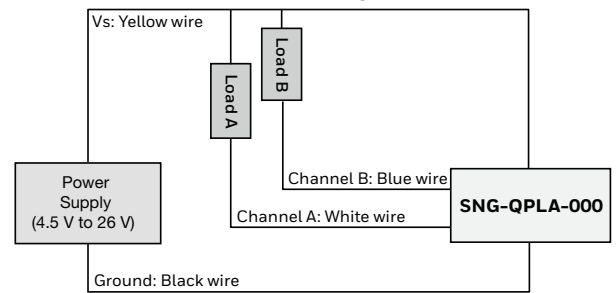

FIGURE 4. SNG-QPLA-000 MOUNTING DIMENSIONS (FOR REFERENCE ONLY: MM/[IN].)



Circuit Diagram



Note: The load resistor values should be such that the output current does not exceed the maximum load current of 40 mA.

Use Ohm's Law to calculate the load resistor based on the supply/load voltage used:

$$R = V / 0.04 A$$

Leadwire Assignment

Yellow	Black	White	Blue
Vsupply	Ground	Channel A	Channel B

QUADRATURE SPEED AND DIRECTION SENSORS SNG-Q SERIES

FIGURE 5. SNG-QPCA-001 MOUNTING DIMENSIONS (FOR REFERENCE ONLY: MM/[IN].)

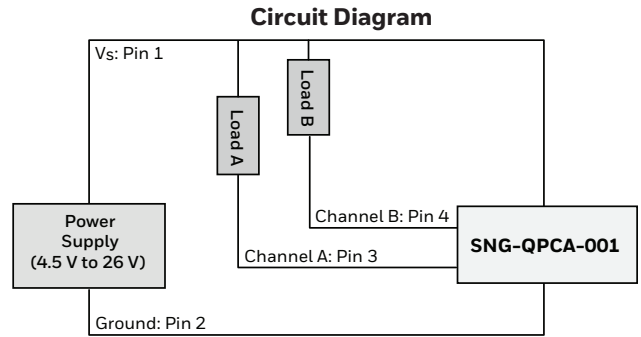
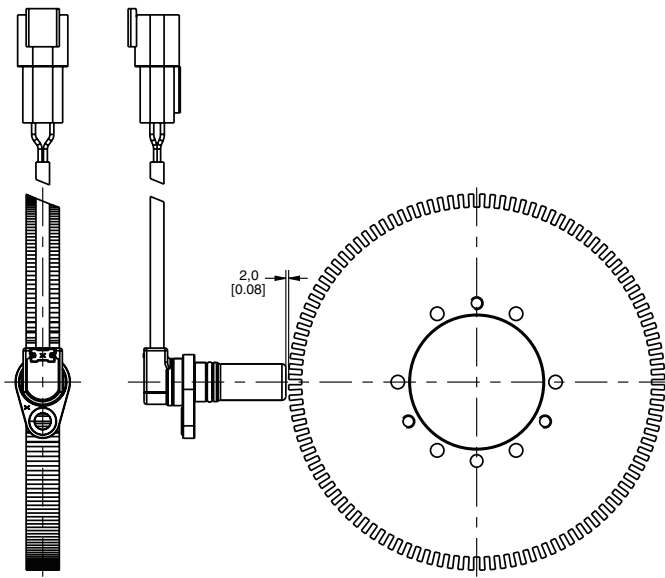

Note: The load resistor values should be such that the output current does not exceed the maximum load current of 40 mA.

Use Ohm's Law to calculate the load resistor based on the supply/load voltage used:

$$R = V / 0.04 \text{ A}$$

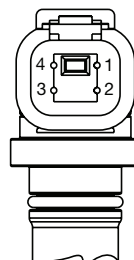
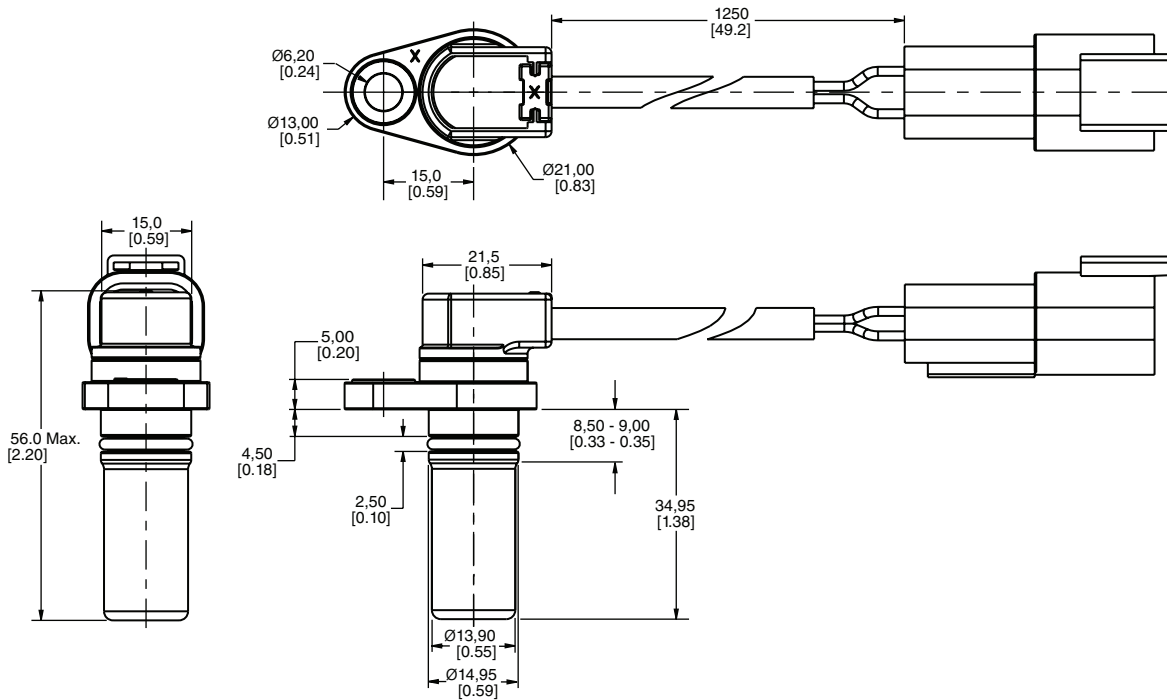

Deutsch DTM04-4P Pinout (mating connector is Deutsch DTM06-4S)			
Pin 1	Pin 2	Pin 3	Pin 4
Vsupply	Ground	Channel A	Channel B

QUADRATURE SPEED AND DIRECTION SENSORS SNG-Q SERIES

FIGURE 6. SNG-QPRA-000 MOUNTING DIMENSIONS (FOR REFERENCE ONLY: MM/[IN.])

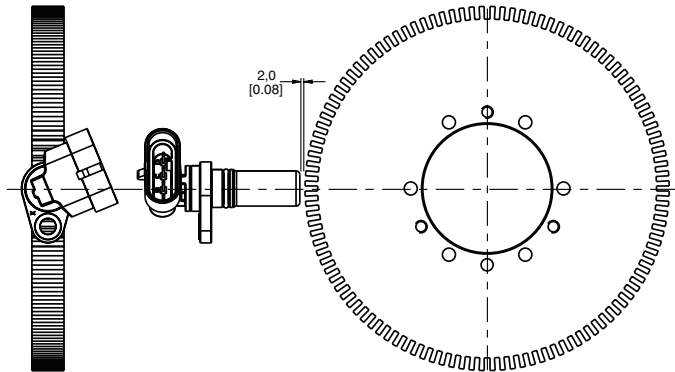

Circuit Diagram

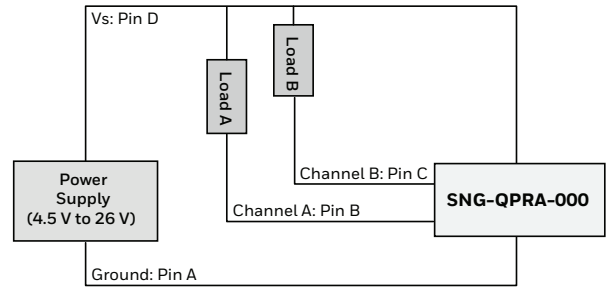

Note: The load resistor values should be such that the output current does not exceed the maximum load current of 40 mA.

Use Ohm's Law to calculate the load resistor based on the supply/load voltage used:

$$R = V / 0.04 \text{ A}$$

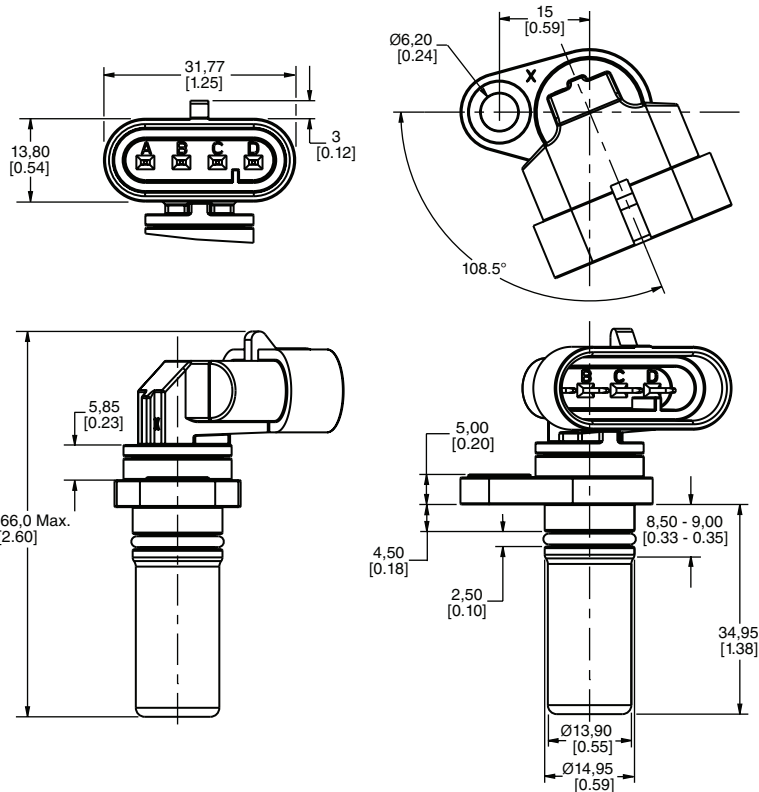

Amp Superseal 1.5 Connector Pinout (mating connector is Amp Superseal 1.5 282088)

Pin A	Pin B	Pin C	Pin D
Ground	Channel A	Channel B	Vsupply

QUADRATURE SPEED AND DIRECTION SENSORS SNG-Q SERIES

FIGURE 7. SNG-QPMB-000 MOUNTING DIMENSIONS (FOR REFERENCE ONLY: MM/[IN.])

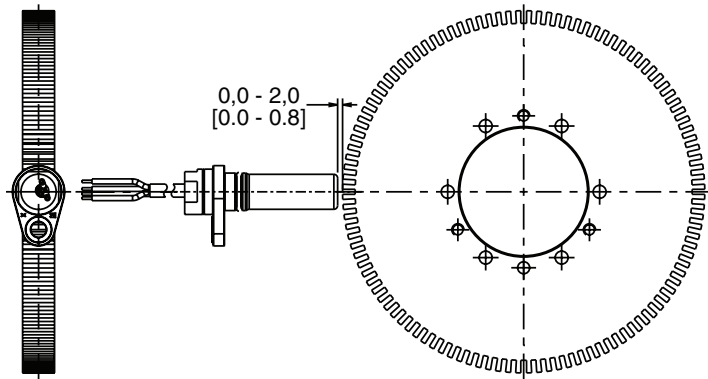

Circuit Diagram

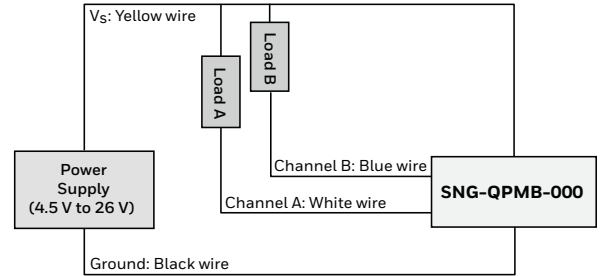

Note: The load resistor values should be such that the output current does not exceed the maximum load current of 40 mA.

Use Ohm's Law to calculate the load resistor based on the supply/load voltage used:

$$R = V / 0.04 \text{ A}$$

Leadwire Assignment

Yellow	Black	White	Blue
Vsupply	Ground	Channel A	Channel B

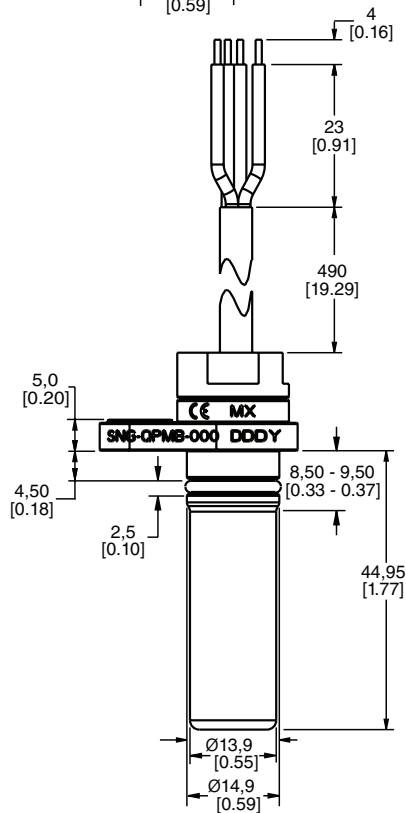
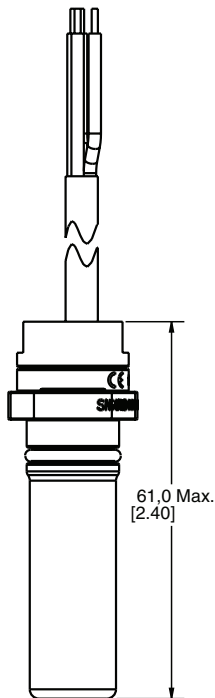
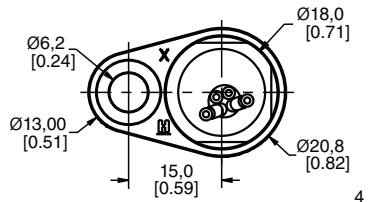

QUADRATURE SPEED AND DIRECTION SENSORS SNG-Q SERIES

FIGURE 8. SNG-QPDB-000 MOUNTING DIMENSIONS (FOR REFERENCE ONLY: MM/[IN.])

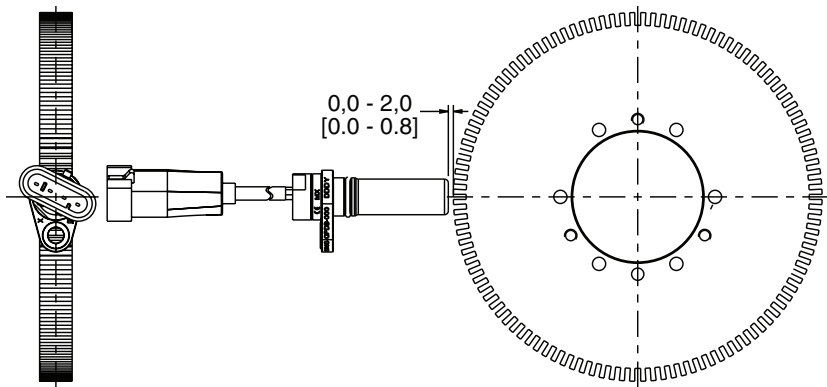

Circuit Diagram

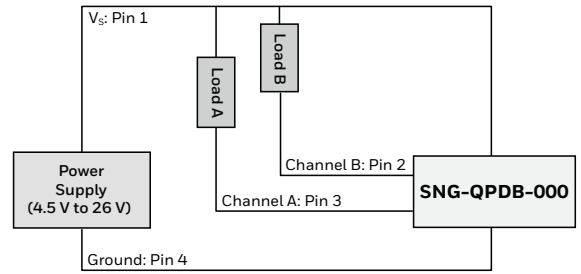

Note: The load resistor values should be such that the output current does not exceed the maximum load current of 40 mA.

Use Ohm's Law to calculate the load resistor based on the supply/load voltage used:

$$R = V / 0.04 \text{ A}$$

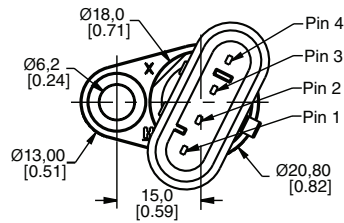

**Amp Superseal 1.5 282106 Pinout
(mating connector is Amp Superseal 1.5 282088)**

Pin 1	Pin 2	Pin 3	Pin 4
Vsupply	Channel B	Channel A	Ground

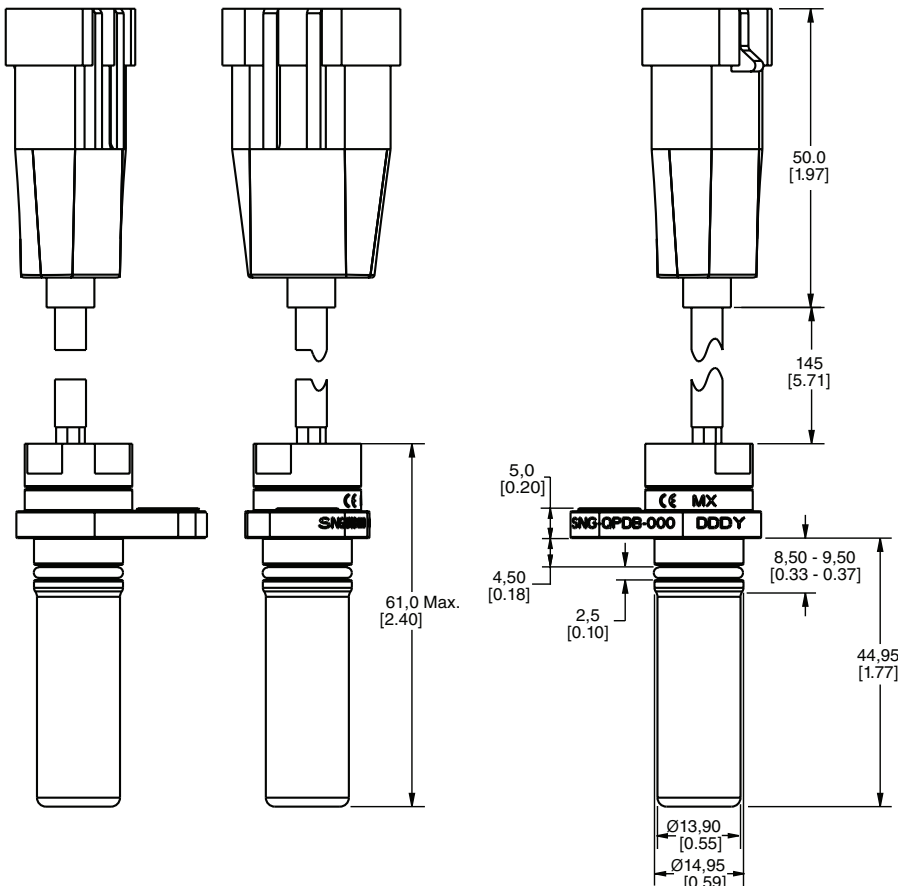

QUADRATURE SPEED AND DIRECTION SENSORS SNG-Q SERIES

FIGURE 9. SNG-QPDB-002 MOUNTING DIMENSIONS (FOR REFERENCE ONLY: MM/[IN].)

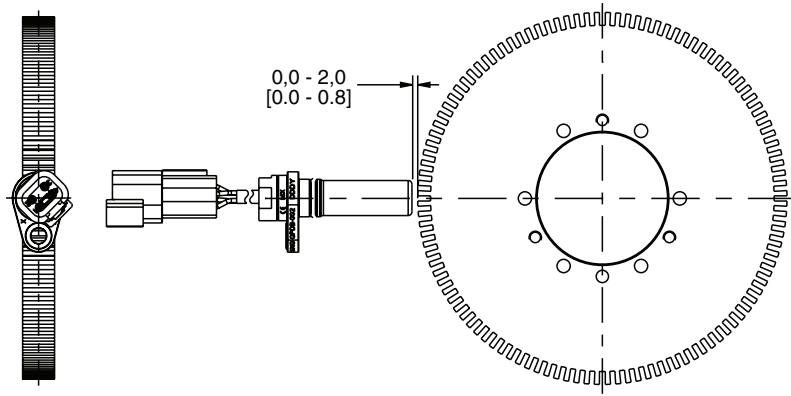

Circuit Diagram

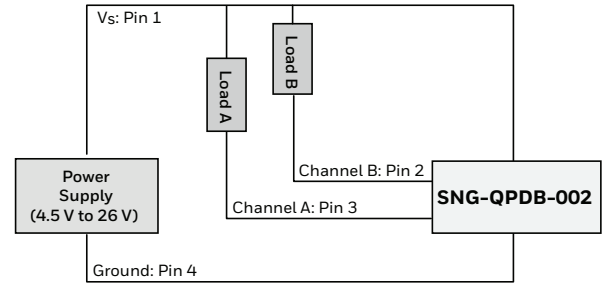

Note: The load resistor values should be such that the output current does not exceed the maximum load current of 40 mA.

Use Ohm's Law to calculate the load resistor based on the supply/load voltage used:

$$R = V / 0.04 \text{ A}$$

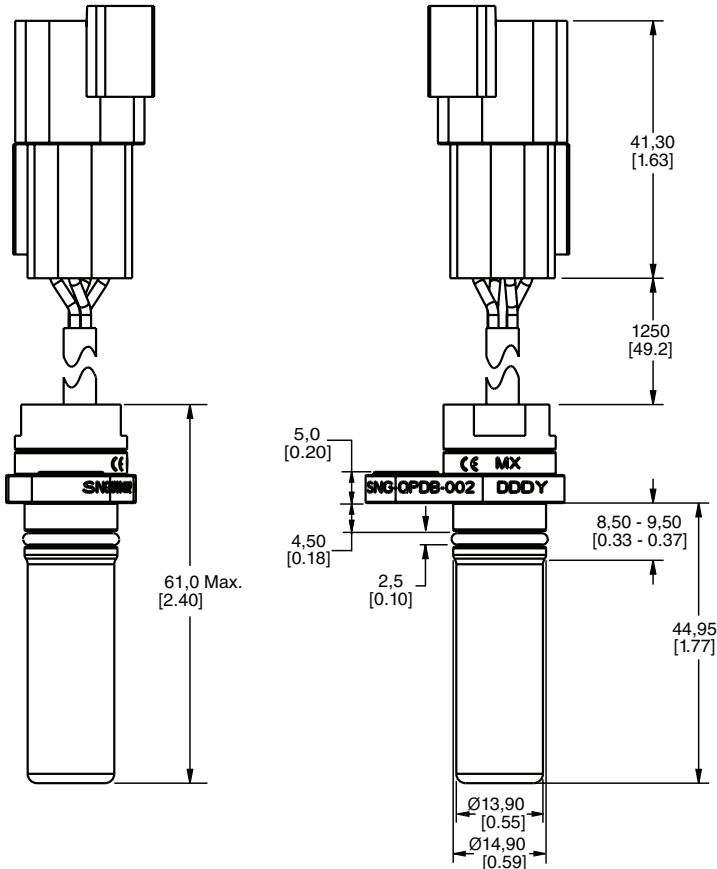
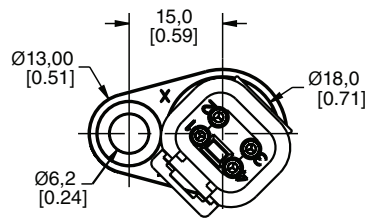

Deutsch DTM04-4P Pinout (mating connector is Deutsch DTM06-4S)

Pin 1	Pin 2	Pin 3	Pin 4
Vsupply	Channel B	Channel A	Ground

ADDITIONAL MATERIALS

The following associated literature is available at sensing.honeywell.com:

- Product Range Guide
- Product Line Guide
- Product Installation Instructions
- Application notes

WARRANTY/REMEDY

Honeywell warrants goods of its manufacture as being free of defective materials and faulty workmanship during the applicable warranty period. Honeywell's standard product warranty applies unless agreed to otherwise by Honeywell in writing; please refer to your order acknowledgment or consult your local sales office for specific warranty details. If warranted goods are returned to Honeywell during the period of coverage, Honeywell will repair or replace, at its option, without charge those items that Honeywell, in its sole discretion, finds defective. **The foregoing is buyer's sole remedy and is in lieu of all other warranties, expressed or implied, including those of merchantability and fitness for a particular purpose. In no event shall Honeywell be liable for consequential, special, or indirect damages.**

While Honeywell may provide application assistance personally, through our literature and the Honeywell web site, it is buyer's sole responsibility to determine the suitability of the product in the application.

Specifications may change without notice. The information we supply is believed to be accurate and reliable as of this writing. However, Honeywell assumes no responsibility for its use.

FOR MORE INFORMATION

Honeywell Advanced Sensing Technologies services its customers through a worldwide network of sales offices and distributors. For application assistance, current specifications, pricing or the nearest Authorized Distributor, visit sps.honeywell.com/ast or call:

USA/Canada	+1 302 613 4491
Latin America	+1 305 805 8188
Europe	+44 1344 238258
Japan	+81 (0) 3-6730-7152
Singapore	+65 6355 2828
Greater China	+86 4006396841

Honeywell Advanced Sensing Technologies

830 East Arapaho Road
Richardson, TX 75081
sps.honeywell.com/ast

WARNING PERSONAL INJURY

DO NOT USE these products as safety or emergency stop devices or in any other application where failure of the product could result in personal injury.

Failure to comply with these instructions could result in death or serious injury.

WARNING MISUSE OF DOCUMENTATION

- The information presented in this product sheet is for reference only. Do not use this document as a product installation guide.
- Complete installation, operation, and maintenance information is provided in the instructions supplied with each product.

Failure to comply with these instructions could result in death or serious injury.