

Product Data Sheet

Product Datasheet

5FO Oxygen

Document Purpose

The purpose of this document is to present the performance specification of the 5FO oxygen sensor.

This document should be used in conjunction with Operating Principles OP02 and the Product Safety Datasheet PSDS 4.

The data provided in this document are valid at 20°C, 50% RH and 1013 mBar for 3 months from the date of sensor manufacture. For guidance on sensor performance outside of these limits, please refer to Operating Principles OP02.

Output signal can drift below the lower limit over time. For guidance on the safe use of the sensor, please refer to Operating Principles OP02.

Product Data Sheet

Key Features and Benefits

- Reliably meets stated life
- Superior environmental performance

Technical Specifications

MEASUREMENT

Technology	Electrochemical
Measurement Range	0-25% vol. O ₂
Maximum Overload	30% vol. O ₂
Output Signal*	0.41 ± 0.05 mA in Air
Response Time (T95)*	<20 Seconds
Linearity	Can be considered linear in many cases. See Operating Principles (OP-02) for further details.

ELECTRICAL

Maximum Load Resistor | 100 Ω

MECHANICAL

Weight	44 g
Orientation Sensitivity	None

ENVIRONMENTAL

Operating Temperature Range	-20°C to +45°C
Recommended Storage Temp	0°C to 20°C
Temperature Coefficient	0.2% signal/°C
Operating Pressure Range	Atmospheric ± 10%
Pressure Coefficient	<0.02% signal/mbar
Operating Humidity Range	0 to 99%RH non-condensing

LIFETIME

Long Term Output Drift*	<5% signal/year
Expected Operating Life	2 years in air
Storage Life	6 months in original packaging

* Specifications are valid at 20°C, 50% RH and 1013 mBar, using recommended circuitry. Performance characteristics outline the performance of sensors supplied within the first 3 months. Output signal can drift below the lower limit over time.

Product Dimensions

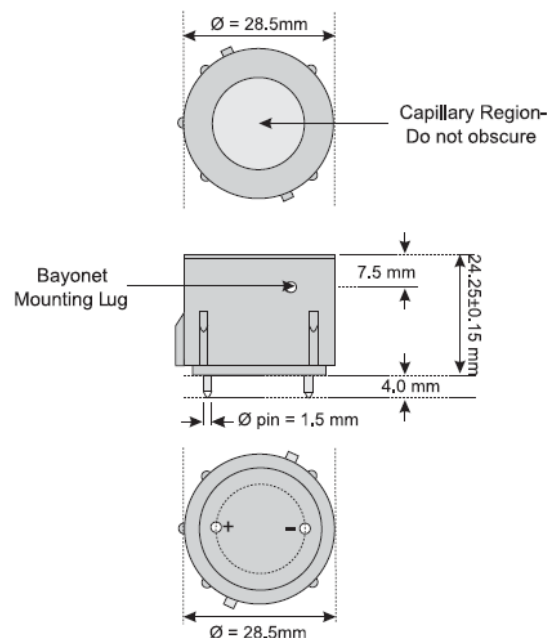

Two pins on 17.0 mm PCD

With Bayonet Fitting

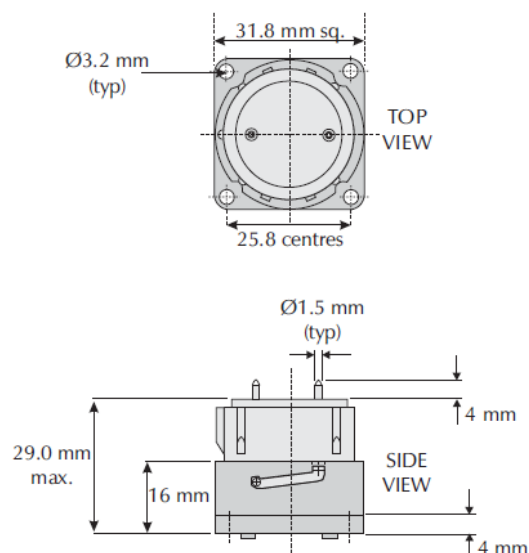

All dimensions in mm.

All tolerances ±0.15 mm unless otherwise stated

IMPORTANT NOTE: Connection should be made via PCB sockets only. Soldering to the pins will seriously damage your sensor and invalidate the warranty.

Product Data Sheet

Poisons

Sensors are designed for operation in a wide range of environments and harsh conditions. However it is important that exposure to high concentrations of solvent vapours is avoided, both during storage, fitting into instruments, and operation. When using sensors with printed circuit boards (PCBs), degreasing agents should be used before the sensor is fitted. Do not glue directly on or near the sensor as the solvent may cause crazing of the plastic.

Cross Sensitivity Data

Toxic gases at TLV levels will have no cross-sensitivity effect on Oxygen sensors. At very high levels (i.e. percent levels), highly oxidising gases (e.g. ozone, chlorine) will interfere to the extent of their oxygen equivalent, but most other commonly occurring gases will have no effect.

Gas	Test Concentration	Balance	%O ₂ Equivalent
Hydrocarbons	100%	NA	0
Methane, CH ₄	100%	NA	0
Hydrogen, H ₂	100%	NA	< -2
Carbon Monoxide, CO	20%	Nitrogen	< -0.5

SAFETY NOTE

This sensor is designed to be used in safety critical applications. To ensure that the sensor and/or instrument in which it is used, are operating properly, it is a requirement that the function of the device is confirmed by exposure to target gas (bump check) before each use of the sensor and/or instrument. Failure to carry out such tests may jeopardise the safety of people and property.

Every effort has been made to ensure the accuracy of this document at the time of printing. In accordance with the company's policy of continued product improvement, the manufacturer reserves the right to make product changes without notice. The products are always subject to a programme of improvement and testing which may result in some changes in the characteristics quoted. As the products may be used by the client in circumstances beyond the knowledge and control of the manufacturer, we cannot give any warranty as to the relevance of these particulars to an application. It is the clients' responsibility to carry out the necessary tests to determine the usefulness of the products and to ensure their safety of operation in a particular application.

